

TLE4997

Programmable Linear Hall Sensor

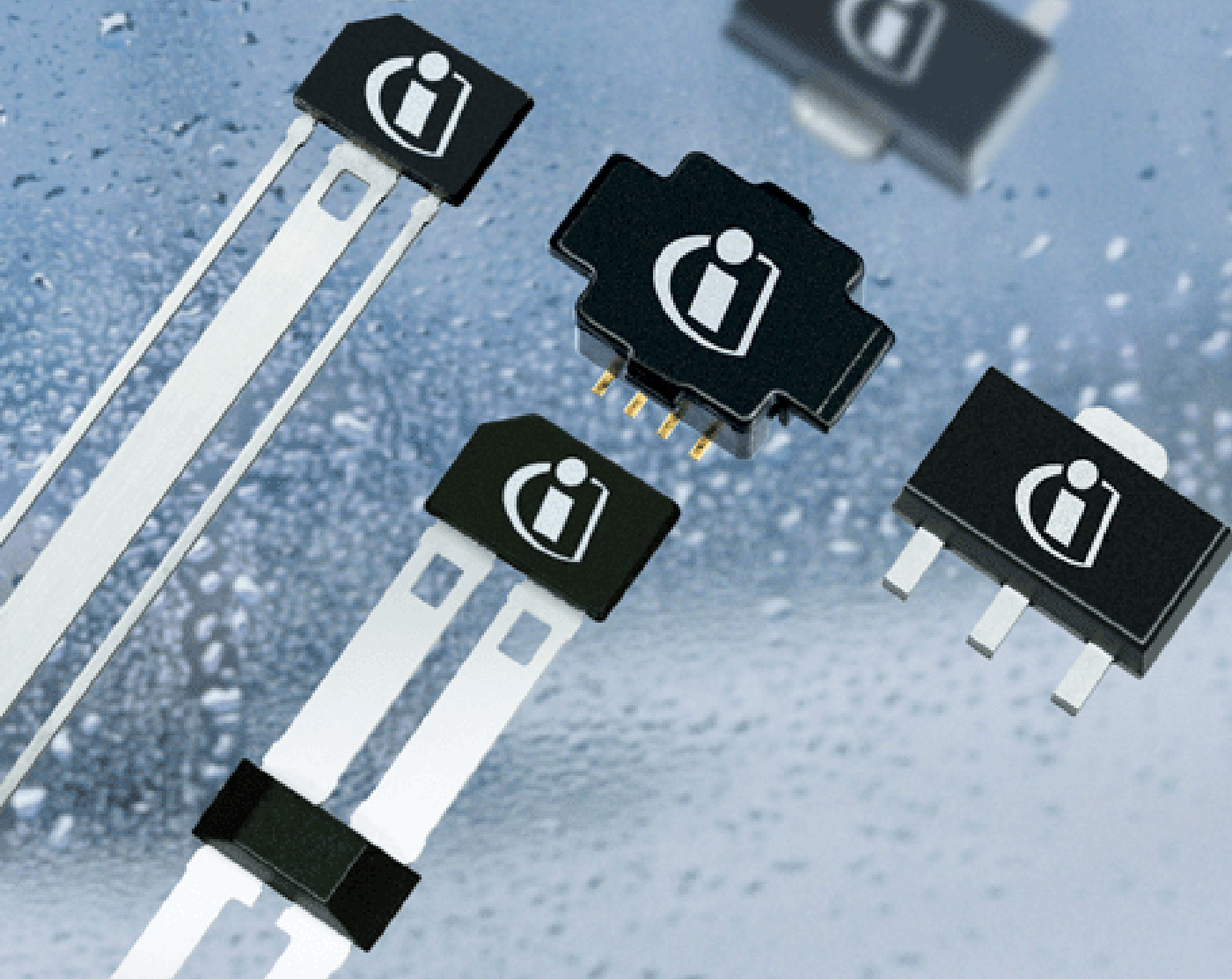

Sensors



Never stop thinking.

Edition 2006-09

**Published by Infineon Technologies AG,
Am Campeon 1-12,
85579 Neubiberg, Germany**

**© Infineon Technologies AG 2006.
All Rights Reserved.**

Attention please!

The information herein is given to describe certain components and shall not be considered as a guarantee of characteristics.

Terms of delivery and rights to technical change reserved.

We hereby disclaim any and all warranties, including but not limited to warranties of non-infringement, regarding circuits, descriptions and charts stated herein.

Information

For further information on technology, delivery terms and conditions and prices please contact your nearest Infineon Technologies Office (www.infineon.com).

Warnings

Due to technical requirements components may contain dangerous substances. For information on the types in question please contact your nearest Infineon Technologies Office.

Infineon Technologies Components may only be used in life-support devices or systems with the express written approval of Infineon Technologies, if a failure of such components can reasonably be expected to cause the failure of that life-support device or system, or to affect the safety or effectiveness of that device or system. Life support devices or systems are intended to be implanted in the human body, or to support and/or maintain and sustain and/or protect human life. If they fail, it is reasonable to assume that the health of the user or other persons may be endangered.

Revision History: 2006-09

V 2.06

Previous Version: V 2.05

Page	Subjects (major changes since last revision)
5	<i>6-inch product removed. Ordering code added: SP000235288.</i>
6	<i>Fig.1: Distance between Hall probe and surface ($0.38\pm 0.03\text{mm} \Rightarrow 0.38\pm 0.05\text{mm}$).</i>
7	<i>Functional description adapted.</i>
8	<i>Principle of operation adapted.</i>
10	<i>Table 2: I_{DDov} max. $25\text{mA} \Rightarrow 52\text{mA}$ (typing error), I_{DDrev} min. $-40\text{mA} \Rightarrow -75\text{mA}$</i>
11	<i>Table 3: R_L pull-up min. $10\text{k}\Omega \Rightarrow 50\text{k}\Omega$</i>
12	<i>Table 4, I_{DD} footnote added: For V_{OUT} within the range of 5% ... 95% of V_{DD}; Table 4, Output DAC resolution: Note deleted.</i>
14	<i>Table 5: S max. $\pm 333\text{mV/mT} \Rightarrow \pm 300\text{mV/mT}$; Calculation of the junction temperature adapted.</i>
15	<i>Magnetic field path and temperature compensation adapted.</i>
18	<i>Footnote 1), Table 10 was omitted.</i>
19	<i>Added: The update rate after the lowpass filter is 16kHz.</i>
20	<i>Added: The update rate after the interpolation filter is 256kHz.</i>
23	<i>Table 13: V_{OUTuv} min. $0.97 \times V_{DD}$ for $3 < V_{DD} \leq V_{DDuv}$ added.</i>
25	<i>Table 16: T_0 min. -32°C /max. $80^\circ\text{C} \Rightarrow$ min. -48°C/max. 64°C</i>
29	<i>Table 18: t_{PRG} min. 30ms/max. $100\text{ms} \Rightarrow$ min. 80ms/max. n/a</i>
30	<i>Application circuit: Note adapted.</i>
general	<i>Changes in data sheet: IFX logo, IFX address, spelling.</i>
general	<i>Temperature specification unified acc. to Infineon guidelines.</i>

We Listen to Your Comments

Any information within this document that you feel is wrong, unclear or missing at all? Your feedback will help us to continuously improve the quality of this document. Please send your proposal (including a reference to this document) to:

feedback.sensors@infineon.com



1	Overview	5
1.1	Features	5
1.2	Target Applications	6
1.3	Pin Configuration	6
2	General	7
2.1	Block Diagram	7
2.2	Functional Description	7
2.3	Principle of Operation	8
2.4	Transfer Functions	9
3	Maximum Ratings	10
4	Operating Range	11
5	Electrical and Magnetic Parameters	12
	Ratiometry	13
	Calculation of the Junction Temperature	14
	Magnetic Parameters	14
6	Signal Processing	15
	Magnetic Field Path	15
	Temperature Compensation	15
6.1	Magnetic Field Ranges	16
6.2	Gain Setting	17
6.3	Offset Setting	17
6.4	DSP Input Low Pass Filter	18
6.5	DAC Input Interpolation Filter	20
6.6	Clamping	21
7	Error detection	23
7.1	Voltages Outside the Normal Operating Range	23
7.2	Open Circuit of Supply Lines	23
7.3	Not correctable EEPROM Errors	24
8	Temperature Compensation	25
8.1	Parameter Calculation	26
9	Calibration	27
9.1	Calibration Data Memory	28
9.2	Programming Interface	29
9.3	Data Transfer Protocol	29
9.4	Programming of Sensors with Common Supply Lines	29
10	Application Circuit	30
11	Package Outlines	31

1 Overview

1.1 Features

- High linear and ratiometric push-pull rail-to-rail output signal
- 20 bit Digital Signal Processing
- Digital temperature compensation
- 12 bit overall resolution
- Operates from -40°C up to 150°C
- Low drift of output signal over temperature and lifetime
- Programmable parameters stored in redundant EEPROM (single bit error correction):
 - magnetic range and magnetic sensitivity (gain)
 - zero field voltage (offset)
 - bandwidth
 - polarity of the output slope
 - clamping option
 - temperature coefficient for all common magnets
 - memory lock
- Re-programmable until memory lock
- Single supply voltage 4.5 - 5.5 V (4 - 7 V in extended range)
- Continuous measurement ranges between -200 mT and +200 mT
- Slim 3 pin package (Green)
- Reverse polarity and overvoltage protection for all pins
- Output short circuit protection
- On board diagnostics (wire breakage detection, under voltage, over voltage)
- Digital readout of internal temperature and magnetic field values in calibration mode.
- Individual programming and operation of multiple sensors with common power supply
- Two point calibration of magnetic transfer function
- Precise calibration without iteration steps
- High immunity against mechanical stress, EMC, ESD

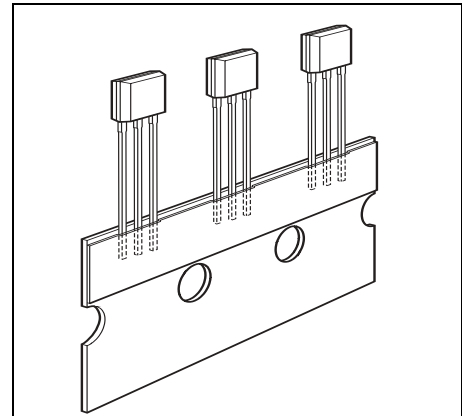

Type	Marking	Ordering Code	Package
TLE4997	4997E2	SP000235288	PG-SSO-3-10

1.2 Target Applications

- Robust replacement of potentiometers
 - No mechanical abrasion
 - Resistant to humidity, temperature, pollution and vibration
- Linear and angular position sensing in automotive applications like pedal position, suspension control, valve or throttle position, headlight levelling and steering angle
- High current sensing for battery management, motor control, and electronic fuse

1.3 Pin Configuration

Figure 1 shows the location of the Hall element in the chip and the distance between Hall probe and surface of the package.

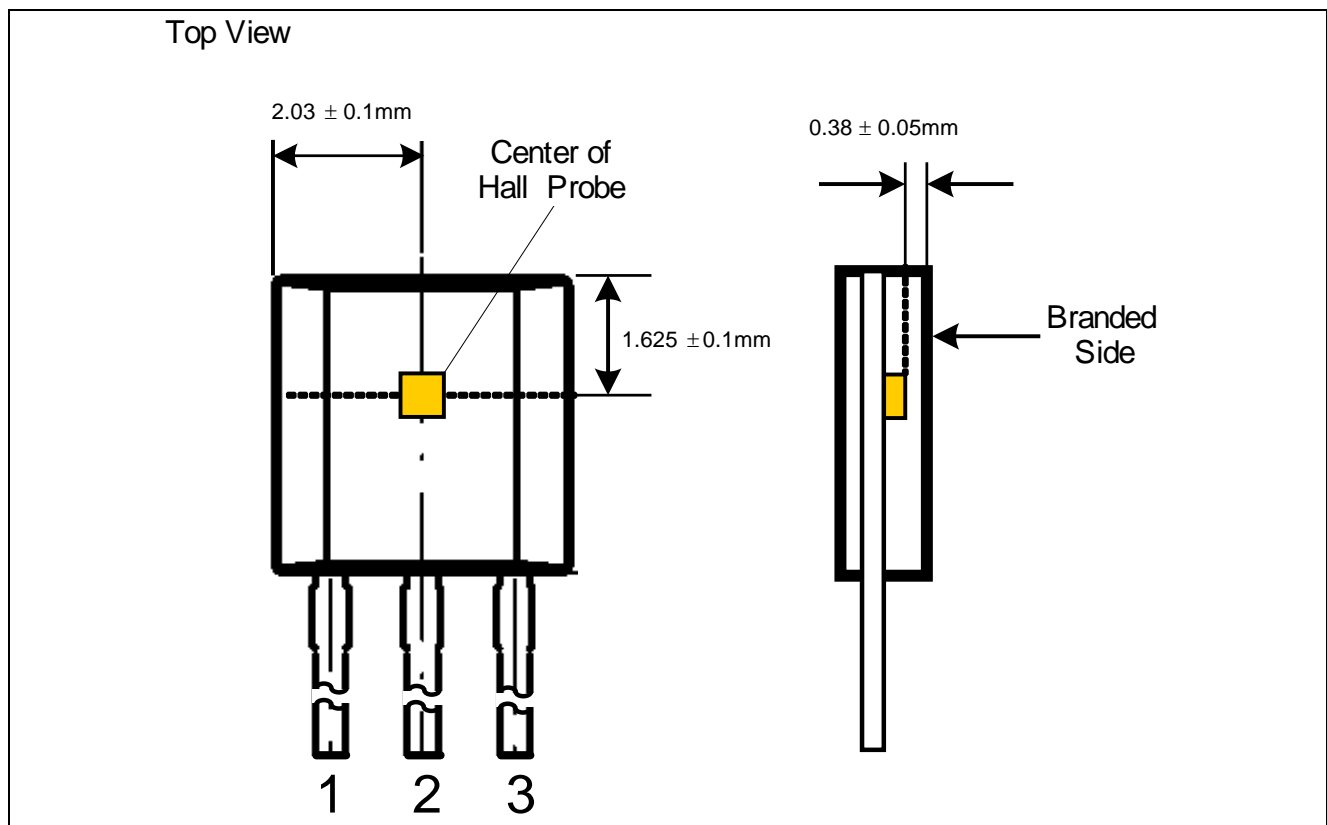

Figure 1 Pin Configuration and Hall Cell Location

Table 1 Pin Definitions and Functions

Pin No.	Symbol	Function
1	V_{DD}	Supply voltage / programming interface
2	GND	Ground
3	OUT	Output voltage / programming interface

2 General

2.1 Block Diagram

Figure 2 shows a simplified block diagram.

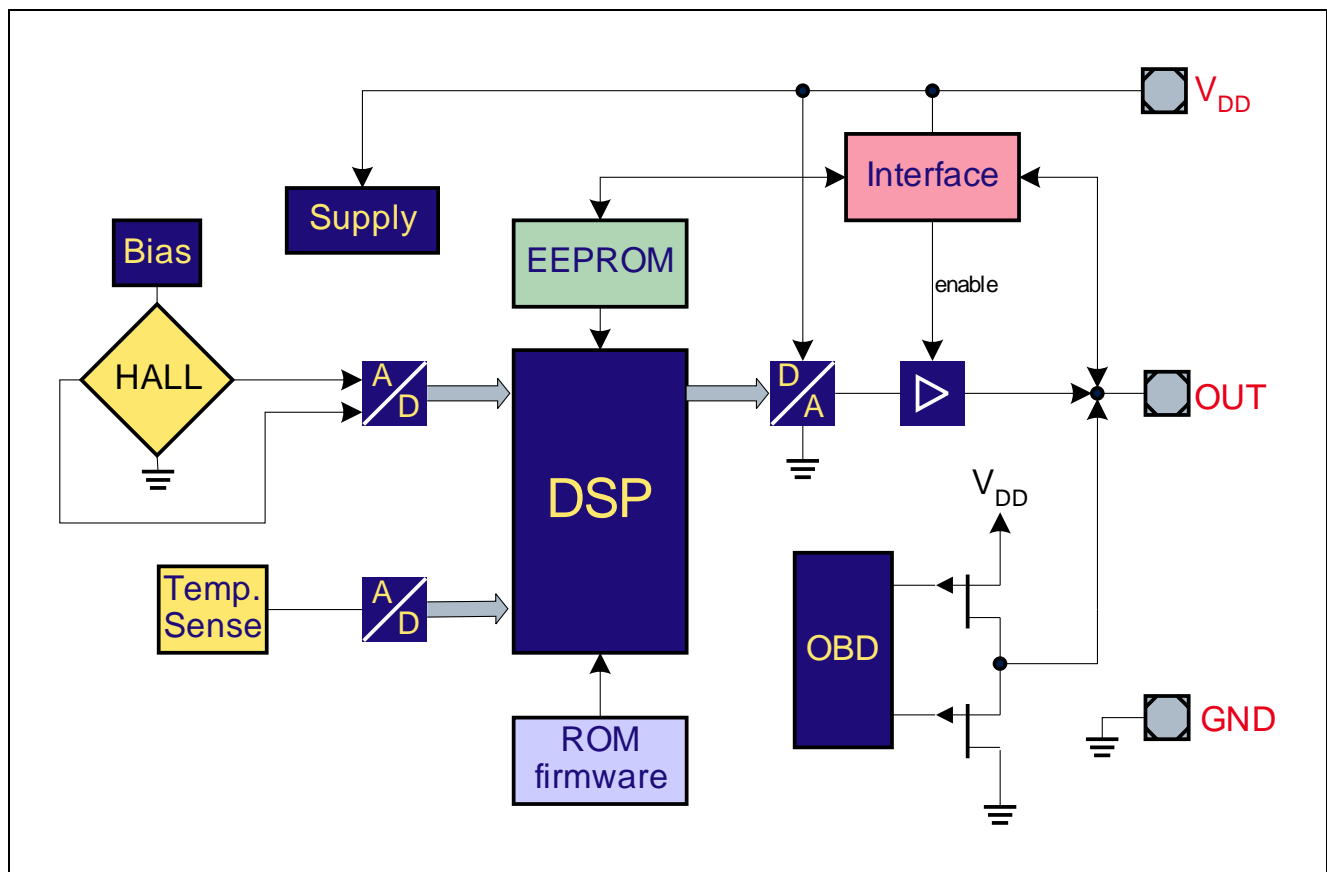

Figure 2 Block Diagram

2.2 Functional Description

The linear Hall IC TLE4997 has been designed specifically to meet the demands of highly accurate rotation and position detection, as well as for current measurement applications.

The sensor provides a ratiometric analog output voltage which is ideally suited for A/D conversion with the supply voltage as a reference.

The IC is produced in BiCMOS technology with high voltage capability and also providing reverse polarity protection.

Digital signal processing using a 16 bit DSP architecture and digital temperature compensation guarantee an excellent long-time stability compared to analog compensation methods.

The minimum overall resolution is 12 bits. Nevertheless some internal stages work with resolutions up to 20 bits.

2.3 Principle of Operation

- A magnetic flux is measured by a Hall-effect cell.
- The output signal from the Hall-effect cell is A to D converted.
- The chopped Hall-effect cell and continuous-time A to D conversion provide very low and stable magnetic offset.
- A programmable low pass filter reduces the noise.
- The temperature is measured and A to D converted.
- Temperature compensation is processed digitally using a second order function.
- Digital processing of output voltage based on zero field and sensitivity value.
- The output voltage range can be clamped by digital limiters.
- The final output value is D to A converted.
- The output voltage is proportional to the supply voltage (ratiometric DAC).
- An OBD (**O**n-**B**oard-**D**iagnostics) circuit connects the output to V_{DD} or GND in case of errors.

2.4 Transfer Functions

The examples in **Figure 3** show how flexible different magnetic field ranges can be mapped to the output voltage.

- Polarity mode:
 - **Unipolar:** Only North or South oriented magnetic fields are measured.
 - **Bipolar:** Magnetic fields can be measured in both orientations. The limit points must not be symmetric to the zero field point.
- Inversion: The gain values can be set positive or negative.

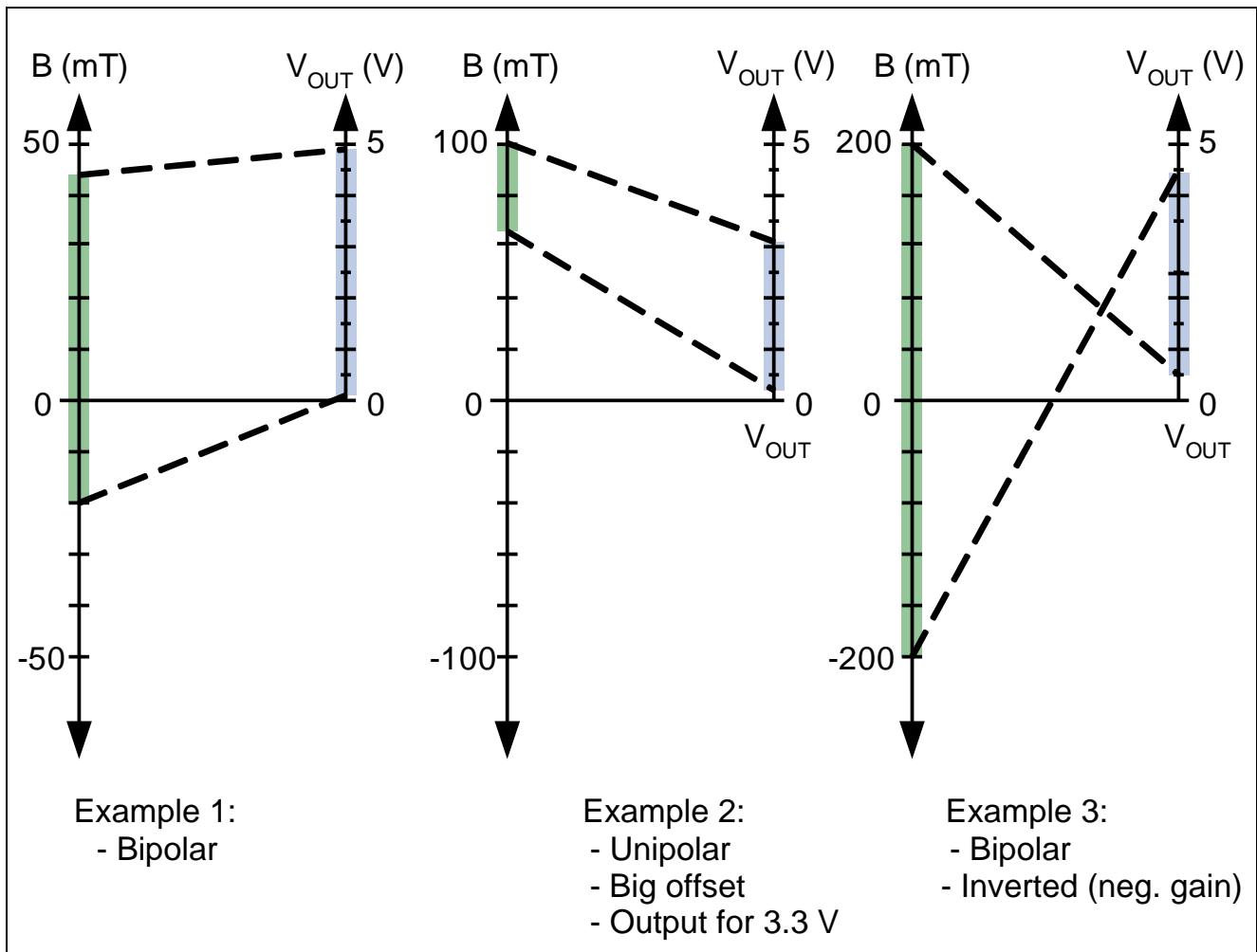

Figure 3 Examples of Operation

Note: Due to the ratiometry also any voltage drops at the V_{DD} line are imaged in the output signal.

3 Maximum Ratings

Table 2 Absolute Maximum Ratings

Parameter	Symbol	Limit Values		Unit	Notes
		min.	max.		
Storage temperature	T_{ST}	- 40	150	°C	
Junction temperature	T_J	- 40	170	°C	
Voltage on V_{DD} pins with respect to ground (V_{SS})	V_{DD}	-20 ¹⁾	20 ²⁾	V	³⁾
Supply current @ overvoltage	I_{DDov}	-	52	mA	
Supply current @ reverse voltage	I_{DDrev}	- 75	-	mA	
Voltage on output pin with respect to ground (V_{SS})	V_{OUTov}	-16 ⁴⁾	16 ²⁾	V	^{3) 5)}
Magnetic field	B_{MAX}	-	unlimited	T	
ESD protection	V_{ESD}	-	2.0	kV	According HBM JESD22-A114-B ⁶⁾

1) max 24 h @ $-50^{\circ}\text{C} \leq T_J < 30^{\circ}\text{C}$
max 10 min. @ $30^{\circ}\text{C} \leq T_J < 80^{\circ}\text{C}$
max 30 sec. @ $80^{\circ}\text{C} \leq T_J < 125^{\circ}\text{C}$
max 15 sec. @ $125^{\circ}\text{C} \leq T_J \leq 150^{\circ}\text{C}$.

2) max. 24 h @ $T_J < 80^{\circ}\text{C}$.

3) $R_{THja} \leq 150 \text{ K/W}$.

4) Max. 1 ms @ $T_J < 30^{\circ}\text{C}$; -8.5 V for 100 h @ $T_J < 80^{\circ}\text{C}$.

5) V_{out} may be $> V_{DD}$

6) 100 pF and 1.5 k Ω

Note: Stresses above those listed under "Absolute Maximum Ratings" may cause permanent damage to the device. This is a stress rating only and functional operation of the device at these or any other conditions above those indicated in the operational sections of this specification is not implied.

Exposure to absolute maximum rating conditions for extended periods may affect device reliability.

During absolute maximum rating overload conditions ($V_{IN} > V_{DD}$ or $V_{IN} < V_{SS}$) the voltage on V_{DD} pins with respect to ground (V_{SS}) must not exceed the values defined by the absolute maximum ratings.

4 Operating Range

The following operating conditions must not be exceeded in order to ensure correct operation of the TLE4997. All parameters specified in the following sections refer to these operating conditions, unless otherwise noticed.

Table 3 Operating Range¹⁾

Parameter	Symbol	Limit Values		Unit	Notes
		min.	max.		
Supply voltage	V_{DD}	4.5	5.5	V	
		4	7	V	Extended Range ²⁾
Load resistance	R_L	10	-	k Ω	pull-down to GND pull-up to V_{DD}
		50	-		
Load capacitance	C_L	0	210	nF	
Junction temperature ³⁾	T_J	-40	125 150	$^{\circ}\text{C}$	for 5000 h for 1000 h ⁴⁾⁵⁾
Useful lifetime	t_{Live}	-	16	years	

1) Keeping signal levels within the limits specified in this table, ensures operation without overload conditions.

2) For reduced output accuracy.

3) $R_{THja} \leq 150 \text{ K/W}$.

4) Not additive.

5) For reduced magnetic accuracy.

Electrical and Magnetic Parameters
5 Electrical and Magnetic Parameters
Table 4 Electrical Characteristics

Parameter	Symbol	Limit Values			Unit	Notes
		min.	typ.	max.		
Output voltage range	V_{OUT}	5 6	-	95 94	% of V_{DD}	for $T_J \leq 120^\circ\text{C}$ for $T_J > 120^\circ\text{C}$
Supply current	I_{DD}	3	7.5	10	mA	in extend. V_{DD} range ¹⁾
Output Current @ OUT shorted to supply lines	I_{OUTsh}	-30	-	30	mA	for operating supply voltage range only
Zero field voltage	V_{ZERO}	-100		100	%	of V_{DD} ²⁾
Zero field voltage drift	ΔV_{ZERO}	-10	-	10	mV	in lifetime ³⁾
		-10	-	10	mV	error band ov. temp. ³⁾
Ratiometry error	E_{RAT}	-0.25	-	+0.25	%	of V_{DD} ⁴⁾⁵⁾
Thermal resistance	R_{thJA}	-	-	219	K/W	junction to air
	R_{thJC}	-	-	47	K/W	junction to case
Power on time	t_{Pon}	-	-	1 10	ms	$\Delta V_{OUT} \leq \pm 5\%$ of V_{DD} $\Delta V_{OUT} \leq \pm 1\%$ of V_{DD}
Power On Reset level	V_{DDpon}	2	-	4	V	
Output DAC quantization	ΔV_{OUT}	1.22			mV	@ $V_{DD} = 5\text{ V}$
Output DAC resolution	-	12			bit	
Output DAC bandwidth	f_{DAC}	-	3.2	-	kHz	interpolation filter ⁶⁾
Output noise	V_{noise}	-	-	4.68	mV _{pp}	5% exceeded ⁷⁾⁸⁾
Differential non-linearity	DNL	-1	-	1	LSB	of output DAC
Signal delay	t_{DS}	-	-	250	μs	@ 100 Hz ⁹⁾

1) For V_{OUT} within the range of 5% ... 95% of V_{DD} .

2) Programmable in steps of 1.22 mV (@ $V_{DD} = 5\text{ V}$).

3) For sensitivity $S \leq 25\text{ mV/mT}$. For higher sensitivities the magnetic offset drift is dominant. This means that for the precalibrated (typical) 60mV/mT sensitivity the typical output drift might be given due to the allowed magnetic offset tolerance up to $\pm 0.4\text{mT} \times 60\text{ mV/mT} = \pm 24\text{ mV}$.

4) For $4.5\text{V} \leq V_{DD} \leq 5.5\text{V}$ and within nom. V_{OUT} range; see chapter "**Ratiometry**" on Page 13 for details on E_{RAT} .

5) For the maximum error in the extended voltage range see chapter "**Ratiometry**" on Page 13.

6) More information: "**DAC Input Interpolation Filter**" on Page 20.

7) 100mT range, sensitivity 60mV/mT, LP-filter 244Hz, 160Hz external RC lowpass filter as application circuit.

8) '5% exceeded' means, 5 of 100 continuously measured V_{OUT} samples are out of limit.

9) A sinusoidal magnetic field is applied, V_{OUT} shows amplitude of 20% of V_{DD} , no LP filter selected.

Electrical and Magnetic Parameters

Ratiometry

The linear Hall sensor works like a potentiometer. The output voltage is proportional to the supply voltage. The division factor depends on the magnetic field strength.

This behavior is called 'ratiometric'.

The supply voltage V_{DD} should be used as reference for the A / D converter of the μ Controller. In this case variations of V_{DD} are compensated.

The ratiometry error is defined as follows:

$$E_{RAT} = \left(\frac{V_{OUT}(V_{DD})}{V_{DD}} - \frac{V_{OUT}(5V)}{5V} \right) \times 100 \%$$

The ratiometry error band displays as 'Butterfly Curve'.

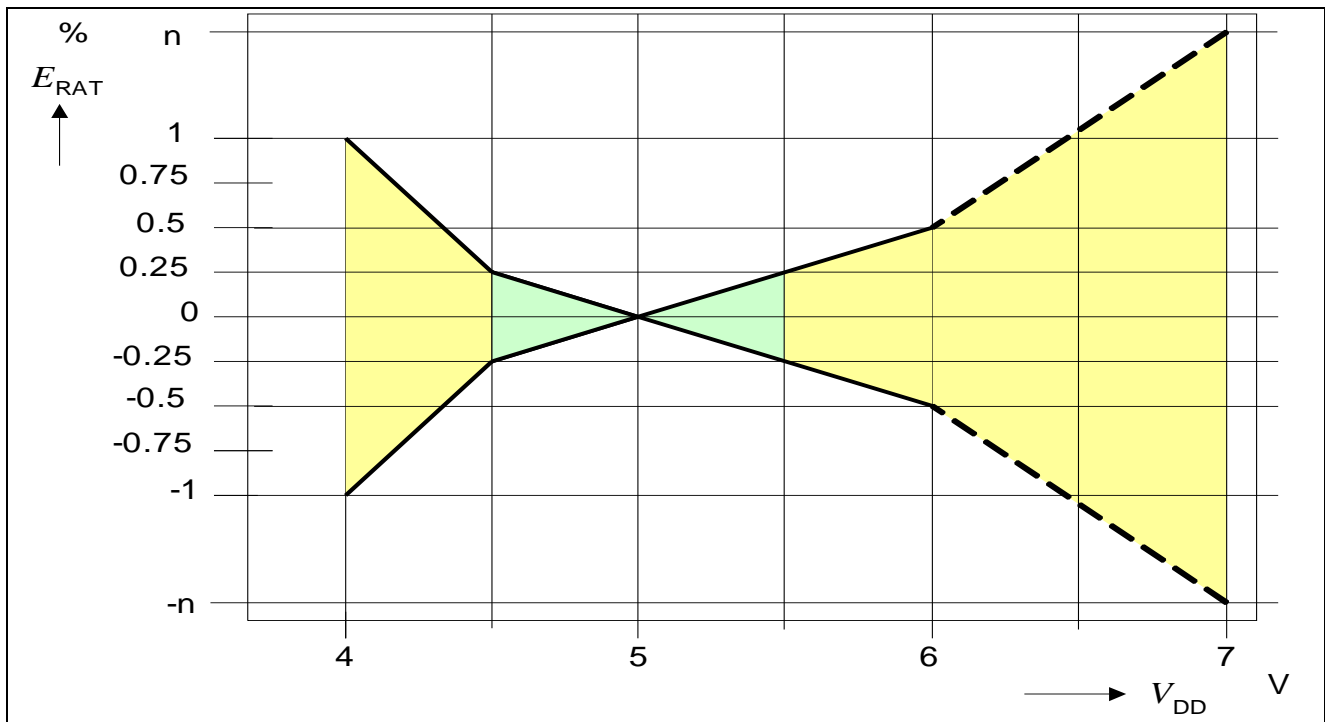

Figure 4 Ratiometry Error Band

The error band in the extended V_{DD} range below 4.5V and above 5.5V is defined as shown in **Figure 4**. In the range from 6 to 7 Volts the error band depends on the output signal. For V_{OUT} lower 20% of V_{DD} the value for n is 2%. For V_{OUT} higher 80% of V_{DD} the value for n is 5%. And if V_{OUT} is kept (clamped) in between, the value for n is 1%.

Note: Take care of possible voltage drops on the V_{DD} and V_{OUT} line degrading the result. Ideally, both values are acquired and their ratio is calculated to gain the highest accuracy. Especially during calibration this method should be used.

Electrical and Magnetic Parameters
Calculation of the Junction Temperature

The own total power dissipation P_{TOT} of the chip increases its temperature above the ambient temperature.

The power multiplied with the total thermal resistance R_{thJA} (Junction to Ambient) leads to the final junction temperature. R_{thJA} is an addition of the components *Junction to Case* and *Case to Ambient*.

$$R_{thJA} = R_{thJC} + R_{thCA}$$

$$T_J = T_A + \Delta T$$

$$\Delta T = R_{thJA} \times P_{TOT} = R_{thJA} \times (V_{DD} \times I_{DD} + V_{OUT} \times I_{OUT}) \quad I_{DD}, I_{OUT} > 0, \text{ if direction is into IC}$$

Example (assuming no noticeable load on Vout):

- $V_{DD} = 5 \text{ V}$
- $I_{DD} = 10 \text{ mA}$
- $\Delta T = 219 \text{ [K/W]} \times (5 \text{ [V]} \times 0.01 \text{ [A]} + 0 \text{ [VA]}) = 11 \text{ K}$

For overmoulded sensors the calculation with R_{thJC} is more adequate.

Magnetic Parameters
Table 5 Magnetic Characteristics

Parameter	Symbol	Limit Values			Unit	Notes
		min.	typ.	max.		
Sensitivity	S	± 12.5	-	± 300	mV/mT	1) 2)
Magnetic field range	MFR	± 50	$\pm 100^{3)}$	± 200	mT	programmable ⁴⁾
Integral nonlinearity	Inl	-15	-	15	mV	$= \pm 0.3\%$ of V_{DD} ⁵⁾
Magnetic offset	B_{OS}	-400	-	400	μT	6) 7) 8)
Magnetic offset drift	ΔB_{OS}	- 5	-	5	$\mu\text{T} / ^\circ\text{C}$	error band ⁷⁾

1) Programmable in steps of 0.024%.

2) @ $V_{DD} = 5\text{V}$ and $T_J = 25^\circ\text{C}$

3) This range is also used for temperature and offset pre-calibration of the IC.

4) Depending on Offset and Gain settings, the output may saturate already at lower fields.

5) $Inl = V_{out} - V_{out,lse}$ with $V_{out,lse}$ = least square error fit of V_{out} .
Valid in the range $(5\% \text{ of } V_{DD}) < V_{OUT} < (95\% \text{ of } V_{DD})$ for $T_J \leq 120^\circ\text{C}$
and $(6\% \text{ of } V_{DD}) < V_{OUT} < (94\% \text{ of } V_{DD})$ for $120^\circ\text{C} < T_J \leq 150^\circ\text{C}$

6) In operating temperature range and over lifetime.

7) For Sensitivity $S > 25 \text{ mV} / \text{mT}$. For lower sensitivities the zero field voltage drift is dominant.

8) Measured at $\pm 100 \text{ mT}$ range.

6 Signal Processing

The flow diagram in **Figure 5** shows the data processing algorithm.

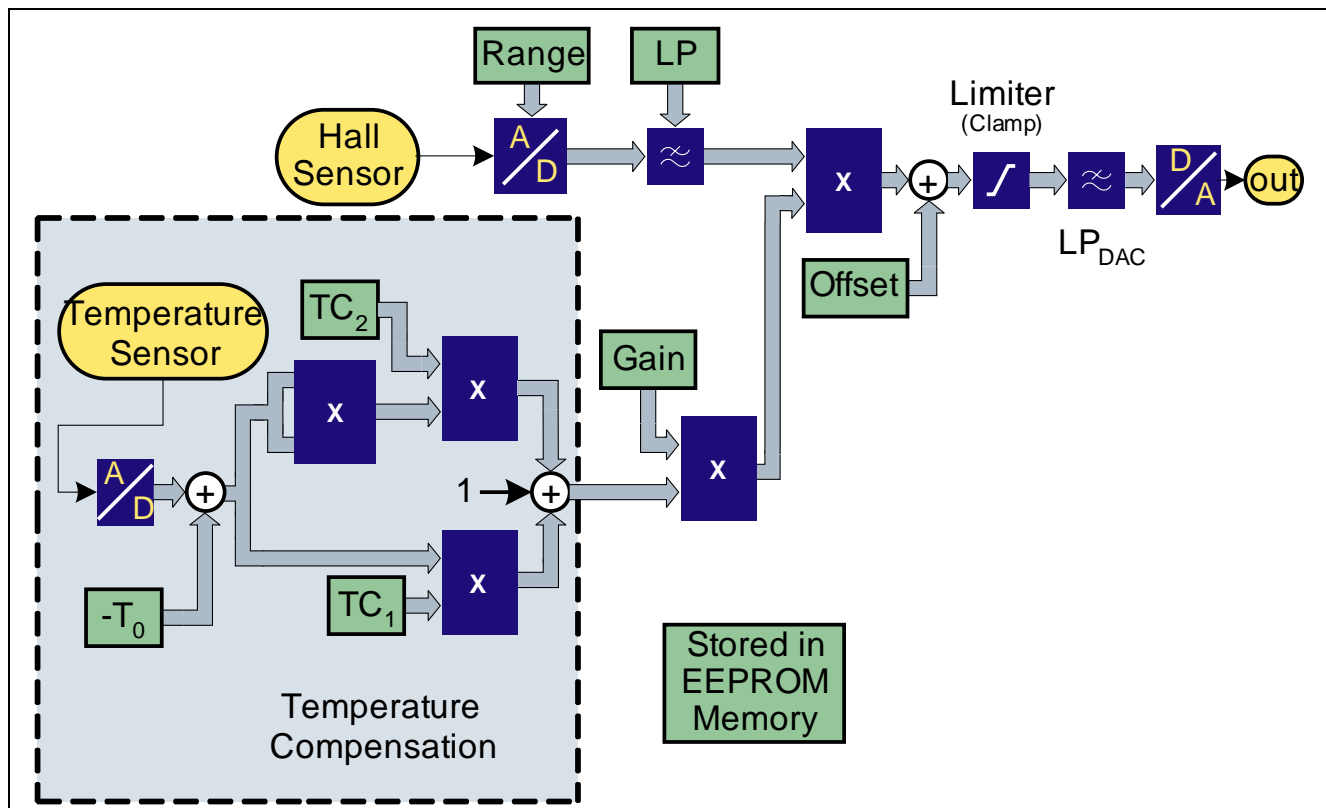

Figure 5 Signal Processing Flow

Magnetic Field Path

- The analog output signal of the chopped Hall cell is converted in the continuous-time A/D converter. The range of the chopped ADC can be set in several steps (see **Table 6**). This gives a suitable level for the A/D converter.
- After the A / D conversion a digital low pass filter reduces the band width (**Table 10**).
- A multiplier amplifies the value according to the gain setting (see **Table 8**) plus temperature compensation.
- The offset value is added (see **Table 9**)
- A limiter reduces the resulting signal to 12 bits and feeds the D / A converter.

Temperature compensation

(Details are listed in **Chapter 8**)

- The output signal of the temperature cell is also A / D converted.
- The temperature is normalized by subtraction of the reference temperature T_0 (zero point of the quadratic function).
- The linear path is multiplied with the TC_1 value.

Signal Processing

- In the quadratic path, the temperature difference to T_0 is squared and multiplied with the TC_2 value.
- Both path outputs are added together to the gain value from the EEPROM.

6.1 Magnetic Field Ranges

The working range of the magnetic field defines the input range of the A to D converter. It is always symmetric to the zero field point. In case of fields higher than the range values the output signal may be distorted.

Any two points in the magnetic range can be selected to define the end points of the output curve. The output voltage represents the magnetic field span between them.

The range must be set before the calibration of offset and gain.

Table 6 Range setting

Range	Range in mT	Parameter R
Low	± 50	3
Mid	± 100	1
High	± 200	0

Table 7 Range

Parameter	Symbol	Limit Values		Unit	Notes
		min.	max.		
Register size	<i>R</i>	2		bit	¹⁾

¹⁾ Ranges do not have an guaranteed absolute accuracy. The temperature pre-calibration is performed in the Mid Range (100mT).

6.2 Gain Setting

The sensitivity is defined by the range and the gain setting. The output of the ADC is multiplied with the gain value.

Table 8 Gain

Parameter	Symbol	Limit Values		Unit	Notes
		min.	max.		
Register size	<i>G</i>	15		bit	unsigned integer value
Gain range	<i>Gain</i>	- 4.0	3.9998	-	1)2)
Gain quantization steps	$\Delta Gain$	244.14		ppm	corresponds to 1/4096

1) For gain values between - 0.5 and + 0.5 the numeric accuracy decreases.

To get a flatter output curve it is recommended to select a higher range setting.

2) A gain value of +1.0 corresponds to typical 40mV/mT sensitivity (100mT range). Infineon pre-calibrates the samples to 60mV/mT (100mT range) in the final test, but does not guarantee the accuracy of this calibration. Therefore it is crucial to do a final calibration of each IC within the application using the Gain/ V_{OS} value.

The gain value can be calculated by

$$Gain = \frac{(G - 16384)}{4096}$$

6.3 Offset Setting

The offset voltage corresponds to an output voltage with zero field at the sensor.

Table 9 Offset

Parameter	Symbol	Limit Values		Unit	Notes
		min.	max.		
Register size	<i>OS</i>	15		bit	unsigned integer value
Offset range	V_{OS}	-400	399	% V_{DD}	1)
Offset quantization steps	ΔV_{OS}	1.22		mV	@ $V_{DD} = 5 V$ generally $V_{DD} / 4095$

1) Infineon pre-calibrates the samples at zero field to 50% of V_{DD} (100mT range) in the final test, but does not guarantee the accuracy of this calibration. Therefore it is crucial to do a final calibration of each IC within the application using the Gain/ V_{OS} value.

The offset value can be calculated by:

$$V_{OS} = \frac{(OS - 16384)}{4096} \times V_{DD}$$

6.4 DSP Input Low Pass Filter

A digital low pass filter is placed between the Hall ADC and the DSP, this is useful to reduce the noise level.

It has a constant DC amplification of 0dB (this is exactly a gain of 1) which means its setting has no influence on the internal Hall ADC value.

The bandwidth can be set in 8 steps.

Table 10 Low pass filter setting

<i>Note: Parameter LP</i>	Cutoff frequency in Hz (at 3dB attenuation)¹⁾
0	78
1	244
2	421
3	615
4	826
5	1060
6	1320
7	off ²⁾

1) As this is a digital filter running with an RC-based oscillator, the cutoff frequency may vary within $\pm 30\%$.

2) The output low pass-interpolation filter behavior remains as main component in the signal path.

Table 11 Range

Parameter	Symbol	Limit Values		Unit	Notes
		min.	max.		
Register size	<i>LP</i>	3		bit	
Corner frequency variation	Δf	- 30	+ 30	%	

Note: In setting 7 (filter off), the output noise increases. Because of higher DSP load, also the current consumption rises slightly.

Signal Processing

Figure 6 shows the characteristic of the filter as magnitude plot (highest setting is marked).

The “off” position would be a flat 0dB line. In this case, output decimation filter limits the bandwidth of the sensor.

The update rate after the lowpass filter is 16kHz.

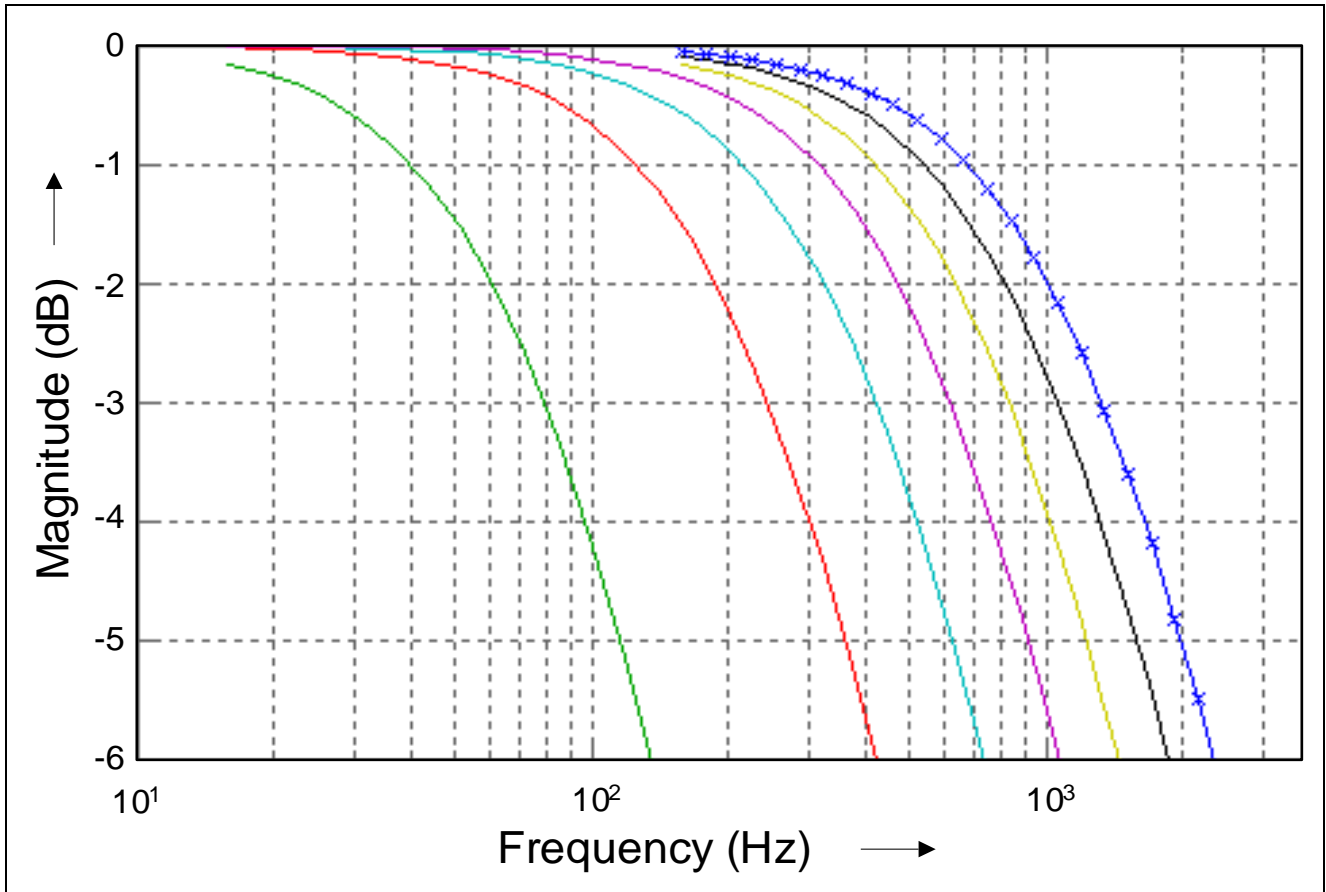

Figure 6 DSP Input Filter (magnitude plot)

6.5 DAC Input Interpolation Filter

Between the DSP and the output DAC an interpolation filter is placed. It can not be switched off.

This filter limits the frequency behavior of the complete system if the DSP input filter is disabled.

The update rate after the interpolation filter is 256kHz.

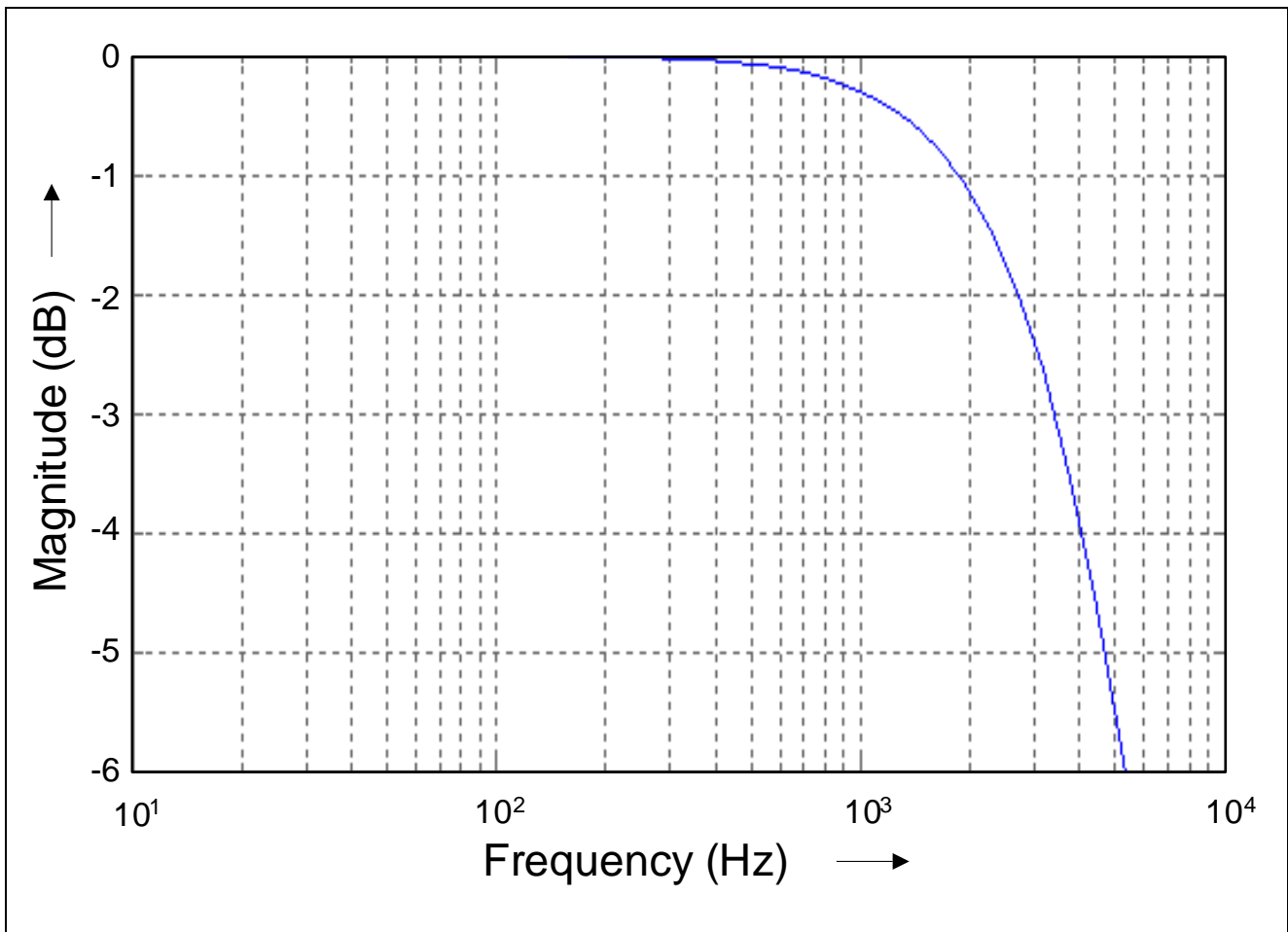

Figure 7 DAC Input Filter (magnitude plot)

Note: As this is a digital filter running with an RC-based oscillator, the cutoff frequency may vary within ±30%.

6.6 Clamping

The clamping function is useful to split the output voltage range into operating range and error ranges.

If the magnetic field is outside the selected measurement range, the output voltage V_{out} is limited to the clamping values.

Table 12 Clamping

Parameter	Symbol	Limit Values		Unit	Notes
		min.	max.		
Register size	CL, CH	2 x 12		bit	
Clamping voltage low	V_{CLL}	0	100	% V_{DD}	1)
Clamping voltage high	V_{CLH}	0	100	% V_{DD}	1)
Clamping quantization steps	ΔV_{CLQ}	1.22		mV	@ $V_{DD} = 5 V$
Clamping voltage drift	ΔV_{CL}	-15	15	mV	in lifetime ²⁾
		-15	15		over temperature ²⁾

1) If clamping is set, it must be within the allowed output voltage range to be effective.

2) Valid in the range (5% of V_{DD}) < V_{OUT} < (95% of V_{DD}) for $T_J \leq 120^\circ C$ and (6% of V_{DD}) < V_{OUT} < (94% of V_{DD}) for $120^\circ C < T_J \leq 150^\circ C$

The clamping values are calculated by:

Clamping low voltage:

$$V_{CLL} = \frac{CL}{4096} \times V_{DD}$$

Clamping high voltage:

$$V_{CLH} = \frac{CH}{4096} \times V_{DD}$$

Note: For an exact setup, the register value may be re-adjusted due to the actual output voltage in clamping condition. The output voltage range itself has electrical limits - see electrical characteristics of V_{out} .

Signal Processing

Figure 8 shows an example, where the magnetic field span between B_{min} and B_{max} is mapped to voltages between 0.8 V and 4.2 V.

If it is not necessary to signal errors, the maximum output voltage range between 0.3 V and 4.7 V can be used.

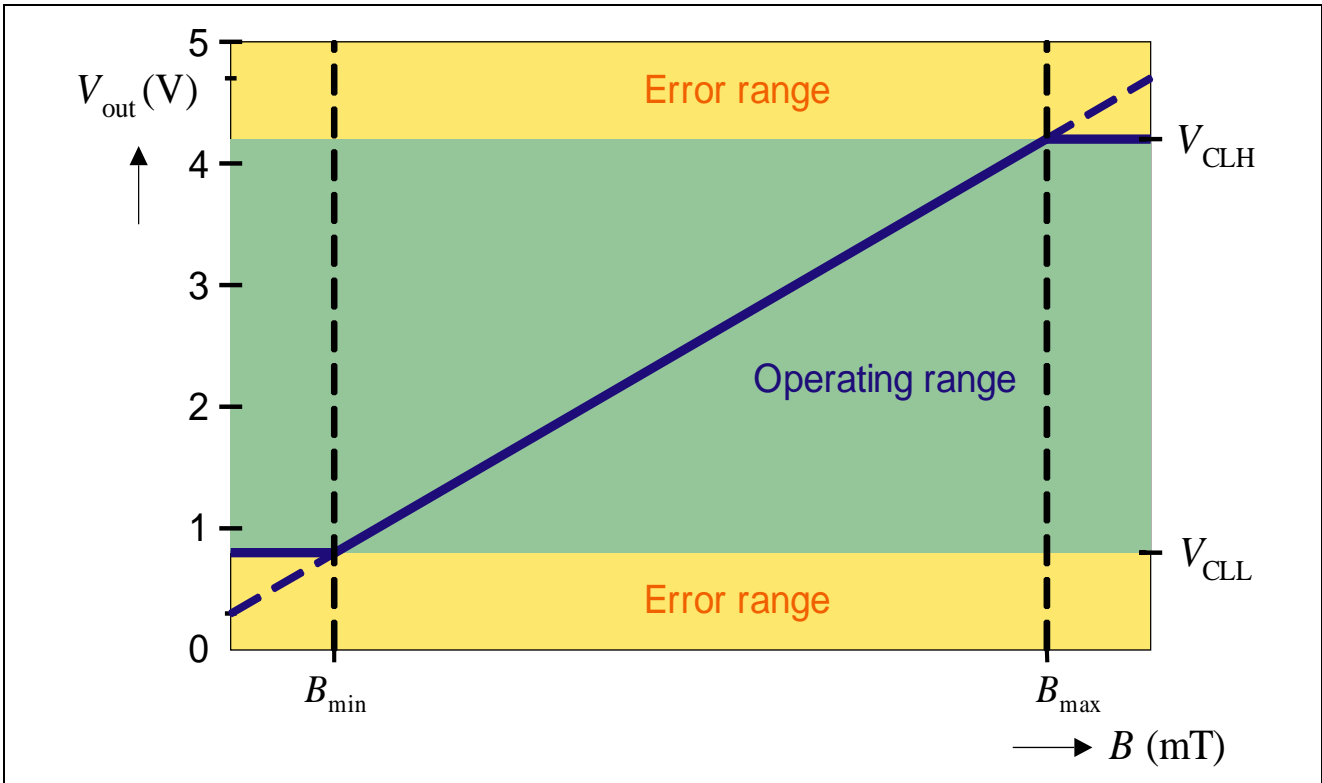

Figure 8 Clamping example

Note: The high value must be above the low value.

If V_{CLL} is set to a higher value than V_{CLH} , the V_{CLH} value is dominating. This would lead to a constant output voltage independent of the magnetic field strength.

7 Error detection

Different error cases can be detected by the OBD (On-Board-Diagnostics) and reported to the μ Controller. The OBD is only useful when the clamping function is enabled. It is important to set the clamping threshold values inside the error voltage values shown in [Table 13](#) and [Table 14](#).

So it is possible to distinguish between correct output voltages and error signals.

7.1 Voltages Outside the Normal Operating Range

The output signals error conditions, if V_{DD} lies

- inside the ratings specified in [Table 2 "Absolute Maximum Ratings" on Page 10](#)
- outside the range specified in [Table 3 "Operating Range" on Page 11](#).

Table 13 Undervoltage and Overvoltage ($R_{LOAD} \geq 10k$ pull down or 50k pull up)

Parameter	Symbol	Limit Values		Unit	Notes
		min.	max.		
Undervoltage threshold	V_{DDuv}	3	4	V	
Overvoltage threshold	V_{DDov}	7	8.3	V	
Output voltage @ Undervoltage	V_{OUTuv}	$0.97 \times V_{DD}$	-	V	$3V < V_{DD} \leq V_{DDuv}$
Output voltage @ Overvoltage	V_{OUTov}	$0.97 \times V_{DD}$	-	V	$V_{DDov} < V_{DD} \leq 16 V$
Supply Current ¹⁾	I_{DDuv}	-	10	mA	@ undervoltage

¹⁾ For overvoltage and reverse voltage see [Table 2 "Absolute Maximum Ratings" on Page 10](#)

7.2 Open Circuit of Supply Lines

In the case of interrupted supply lines, the μ Controller may warn the user. If two sensors are placed in parallel, the output of the remaining working sensor may be still used for an emergency operation.

Table 14 Open circuit (OBD parameters) ¹⁾

Parameter	Symbol	Limit Values		Unit	Notes
		min.	max.		
Output voltage @ open V_{DD} line	V_{OUT}	0	0.18 0.2	V	$T_J \leq 120^\circ C$ $120^\circ C < T_J \leq 150^\circ C$
Output voltage @ open V_{SS} line	V_{OUT}	4.82 4.8	5	V	$T_J \leq 120^\circ C$ $120^\circ C < T_J \leq 150^\circ C$

¹⁾ With $V_{DD} = 5V$ and $R_L \geq 10k\Omega$ pull-down or $R_L \geq 20k\Omega$ pull-up.

7.3 Not correctable EEPROM Errors

The parity method is able to correct one single bit in one EEPROM line.

Single bit errors in further lines will be detected, too. As this situation is not correctable anymore, this status is signalled at the output pin by clamping the output value to V_{DD} .

Table 15 EEPROM Error Signalling

Parameter	Symbol	Limit Values		Unit	Notes
		min.	max.		
Output voltage @ EEPROM error	V_{OUT}	$0.97 \times V_{DD}$	V_{DD}	V	

8 Temperature Compensation

The magnetic field strength of a magnet depends on the temperature. This material constant is specific for the different magnet types. Therefore the TLE4997 offers a second order temperature compensation polynomial, by which the Hall signal output is multiplied in the DSP. There are three parameters for the compensation:

- Reference temperature T_0
- A linear part (1st order) TC_1
- A quadratic part (2nd order) TC_2

Following formula describes the sensitivity dependent on the temperature in relation to the sensitivity at the reference temperature T_0 :

$$S_{TC}(T) = 1 + TC_1 \times (T - T_0) + TC_2 \times (T - T_0)^2$$

For more information see also the signal processing flow in [Figure 5](#).

The full temperature compensation of the complete system is done in three steps:

1. Pre calibration in the Infineon final test.

The parameters TC_1 , TC_2 , T_0 are set to a maximally flat temperature characteristics regarding the Hall probe and internal analog processing parts.

2. Overall System calibration.

The typical coefficients TC_1 , TC_2 , T_0 of the magnetic circuitry are programmed.

This can be done deterministic, as the algorithm of the DSP works fully reproducible.

The final setting of the TC_1 , TC_2 , T_0 values are relatively to the given pre calibrated values.

Table 16 Temperature Compensation

Parameter	Symbol	Limit Values		Unit	Notes
		min.	max.		
Register size TC_1	TL	-	9	bit	unsig. int. values
1 st order coefficient TC_1	TC_1	-1000	2500	ppm/ °C	1)
Quantization steps of TC_1	ΔTC_1	15.26		ppm/ °C	
Register size TC_2	TQ	-	8	bit	unsig. int. values
2 nd order coefficient TC_2	TC_2	- 4	4	ppm/ °C ²	2)
Quantization steps of TC_2	ΔTC_2	0.119		ppm/ °C ²	
Register size T_0	TR	-	3	bit	unsig. int. values
Reference temperature	T_0	- 48	64	°C	
Quantization steps of T_0	ΔT_0	16		°C	

1) Full adjustable range: -2441 to +5355 ppm/°C, can be only used after confirmation by Infineon

2) Full adjustable range: -15 to +15 ppm/°C², can be only used after confirmation by Infineon

Temperature Compensation

8.1 Parameter Calculation

The parameters TC_1 , TC_2 and T_0 may be calculated by:

$$TC_1 = \frac{TL - 160}{65536} \times 1000000$$

$$TC_2 = \frac{TQ - 128}{8388608} \times 1000000$$

$$T_0 = 16TR - 32$$

Now the output V_{OUT} for a given field B_{IN} at a specific temperature can be roughly calculated by:

$$V_{OUT} = \left(\frac{B_{IN}}{B_{FSR}} \times S_{TC} \times S_{TCHall} \times S_o \times V_{DD} \right) + V_{OS}$$

B_{FSR} is the full range magnetic field. It is depending on the range setting (e.g 100 mT). S_o is the nominal sensitivity of the Hall probe times the Gain factor set in the EEPROM. S_{TC} is the temperature dependent sensitivity factor calculated by the DSP.

S_{TCHall} is the temperature behavior of the Hall probe.

The pre-calibration at Infineon is performed in a way that following condition is met:

$$S_{TC}(T) \times S_{TCHall}(T) \approx 1$$

Within the application an additional factor $B_{IN}(T) / B_{IN}(T_0)$ will be given due to the magnetic system. S_{TC} needs now to be modified to S_{TCnew} in a way that overall the next condition is satisfied:

$$\frac{B_{IN}(T)}{B_{IN}(T_0)} \times S_{TCnew}(T) \times S_{TCHall}(T) \approx S_{TC}(T) \times S_{TCHall}(T) \approx 1$$

Therefore the new sensitivity parameters S_{TCnew} can be calculated out of the pre calibrated setup S_{TC} using the relation:

$$\frac{B_{IN}(T)}{B_{IN}(T_0)} \times S_{TCnew}(T) \approx S_{TC}(T)$$

9 Calibration

For the calibration of the sensor, a special hardware interface to an external computing system and measurement equipment is required. All calibration and setup bits can be written into a RAM memory. This allows to keep the EEPROM untouched during the whole calibration process. Therefore this temporary setup (using the RAM only) does not stress the EEPROM - and allows even a pre-verification¹⁾ of the setup before programming - as the number of the EEPROM programming cycles is limited to provide a high data endurance.

The digital signal processing is completely deterministic. This allows a two point calibration in one step without iterations. The two magnetic fields (here described as two “positions” of an external magnetic circuitry) need only to be applied only once. Furthermore, a complete setup and calibration procedure can be performed requiring only one EEPROM programming cycle at the end²⁾.

After setting up the temperature coefficients, the calibrated Hall ADC values of both positions need to be read and the sensor output signals (using a DAC test mode) need to be acquired for the corresponding end points. Using this data, the signal processing parameters can be immediately calculated with a program running on the external computing system.

Please note, the calibration and programming process must be performed at start of life only.

Table 17 Calibration Characteristics

Parameter	Symbol	Limit Values		Unit	Notes
		min.	max.		
Temp. of sensor at 2 point calibr. and programming	t_{CAL}	10	30	°C	
2 point calibration accuracy ¹⁾	ΔV_{CAL1}	-10	10	mV	Position 1
	ΔV_{CAL2}	-10	10	mV	Position 2

¹⁾ Setup and validation performed at start of life.

Note: Depending on the application and external instrumentation setup, the accuracy of the 2 point calibration can be better.

¹⁾ But this feature is not required for a deterministic two point setup to fulfill the specification.

²⁾ Details and basic algorithms for this step are available on request.

9.1 Calibration Data Memory

When the MEMLOCK bits are programmed (two redundant bits), the memory content is frozen and may not be changed anymore. Furthermore the programming interface is locked out and the chip remains in the application mode only. This prevents accidentally programming due to environmental influences.

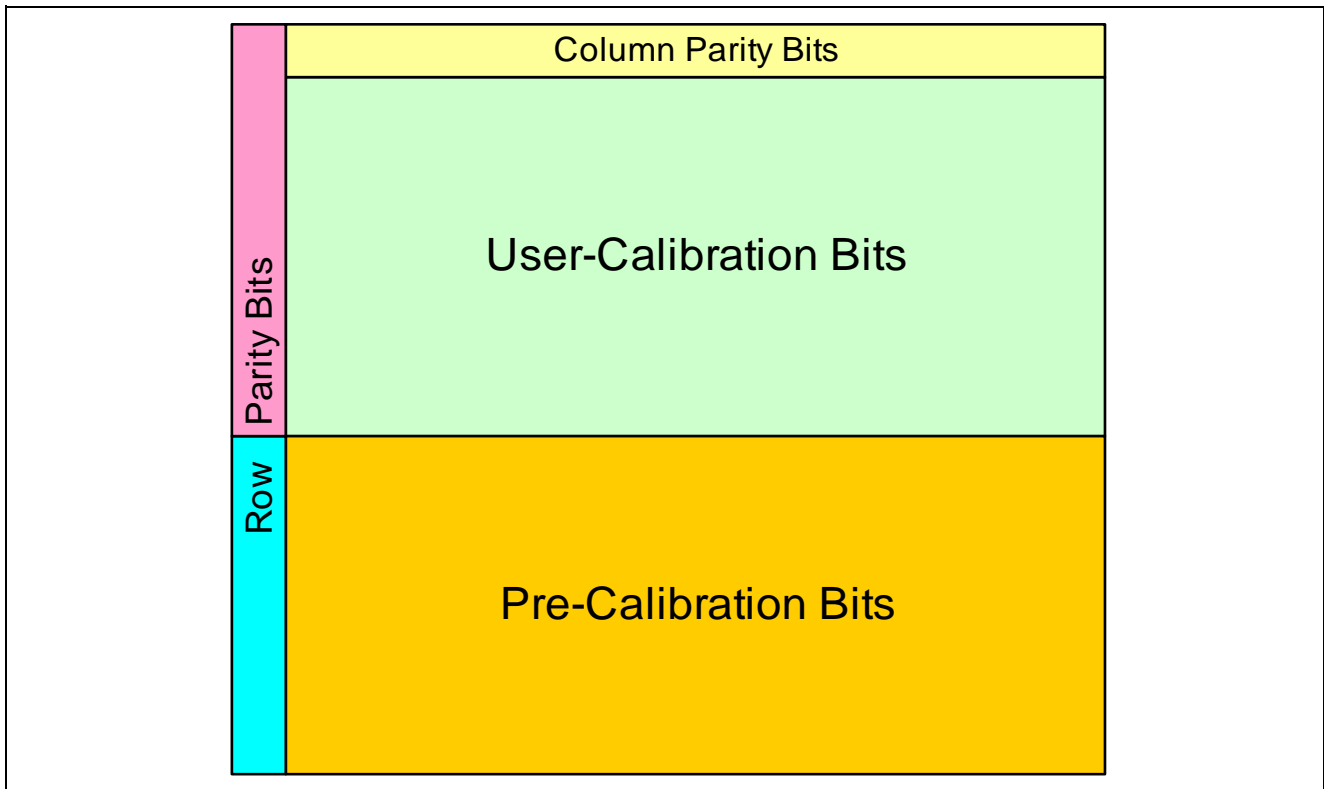

Figure 9 EEPROM Map

A matrix parity architecture allows the automatic correction of any single bit error.

Each row is protected by a row parity bit. The sum of bits set including this bit must be an odd number (ODD PARITY).

Each column is additionally protected by a column parity bit. Each bit in the even positions (0, 2, etc.) of all lines must sum up in an even number (EVEN PARITY), each bit in the odd positions (1,3, etc.) must have an odd sum (ODD PARITY).

This mechanisms of different parity calculations protect also against many block errors (like erasing a full line or even the whole EEPROM).

When modifying the application bits (like Gain, Offset, TC, etc.) the parity bits must be updated. For the column bits, also the pre-calibration area must be read out and considered for correct parity generation.

Note: A specific programming algorithm must be followed to ensure the data retention. A detailed separate programming specification is available on request.

Table 18 Programming Characteristics

Parameter	Symbol	Limit Values		Unit	Notes
		min.	max.		
Number of EEPROM programming cycles	N_{PRG}	-	10	Cycles ¹⁾	Programming only at start of lifetime allowed
Junction temperature at programming	T_{PRG}	10	30	°C	
Programming time	t_{PRG}	80	-	ms	For complete memory ²⁾
Calibration memory	-	135		Bit	all active EEPROM bits
Error Correction	-	25		Bit	all parity EEPROM bits

¹⁾ 1 cycle is the simultaneous change of ≥ 1 bit.

²⁾ Depending on clock frequency at V_{DD} .

9.2 Programming Interface

The supply pin and the output pin are used as two-wire interface to transmit the EEPROM data to and from the sensor.

This allows

- a communication with high data reliability
- the bus-type connection of several sensors

9.3 Data transfer protocol

The data transfer protocol is completely handled by an external programming tool. A evaluation tool running on a standard PC and protocol details are available on request.

9.4 Programming of sensors with common supply lines

In many automotive applications two sensors are used to measure the same parameter. This redundancy allows to continue the operation in an emergency mode. If both sensors use the same power supply lines, they can be programmed together (fully parallel) or separately (sequential), by selection via the different output lines.

10 Application Circuit

Figure 10 shows the connection of multiple sensors to a μ Controller.

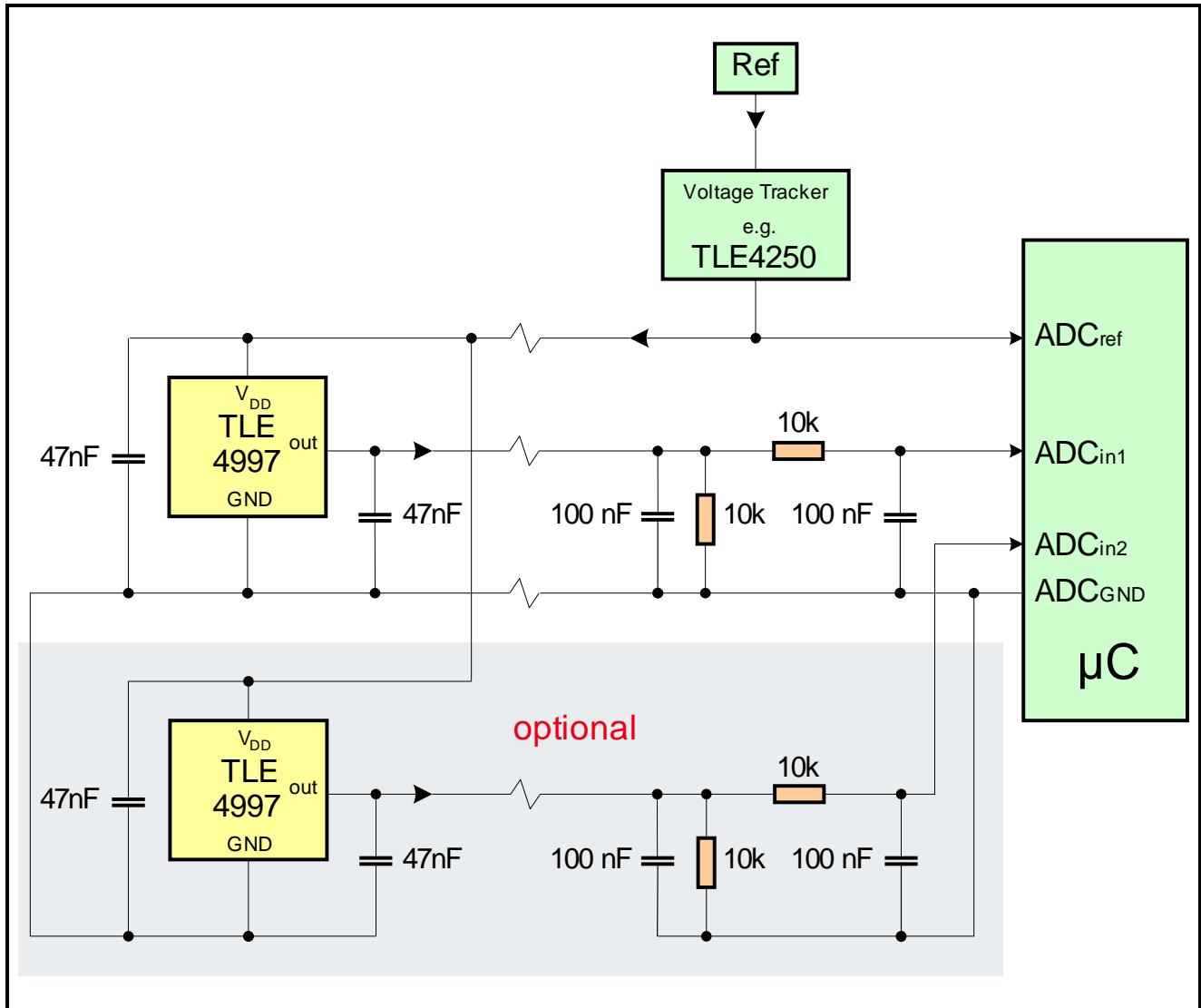

Figure 10 Application Circuit

Note: For calibration and programming, the interface has to be connected directly to the output pin.

The given application circuit has to be understood as an example, needs to be adapted according to the specific requirements of the application.

11 Package outlines

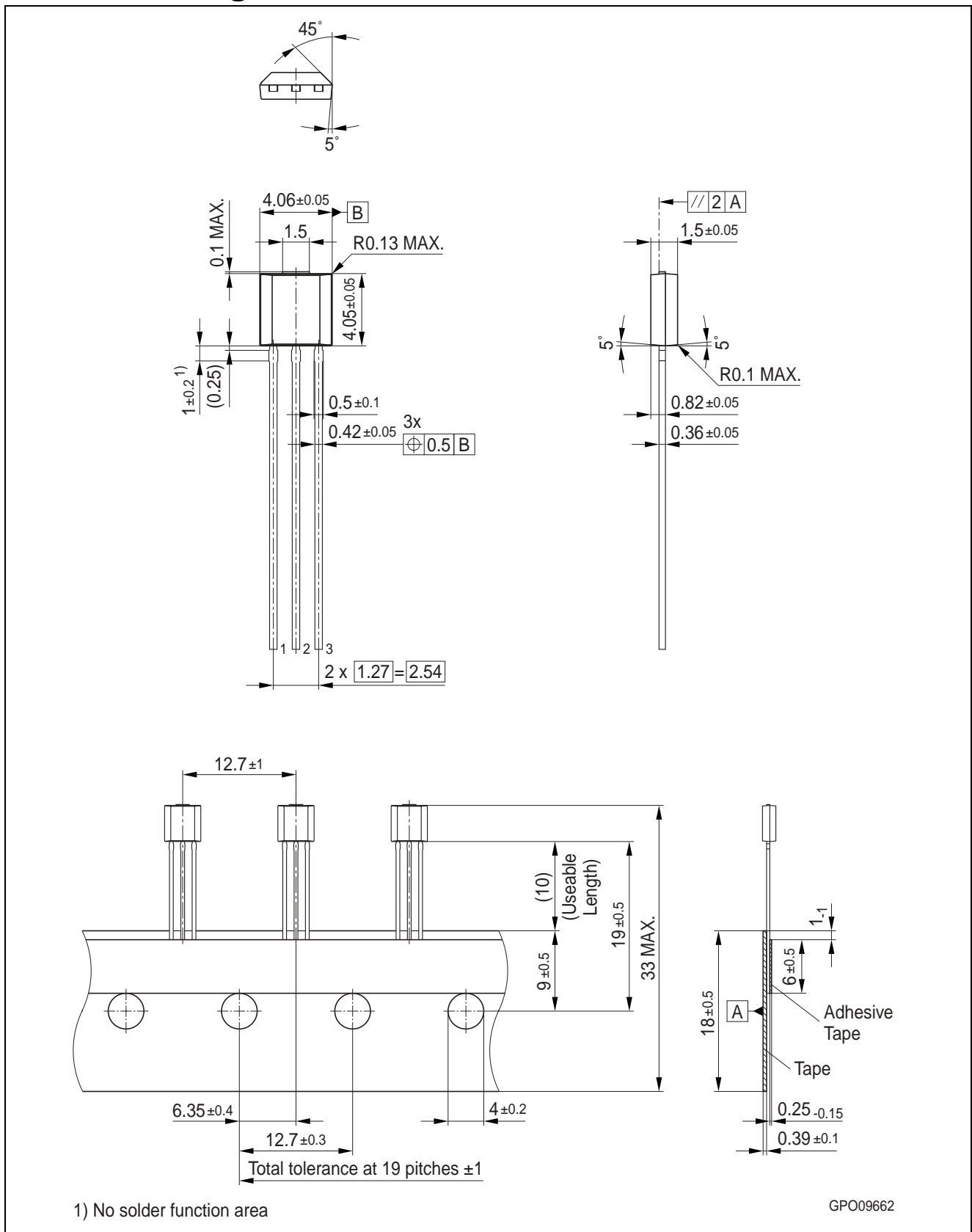

Figure 11 PG-SSO-3-10 (Plastic Green Single Small Outline Package)

www.infineon.com

Published by Infineon Technologies AG